

# ACCESS WITH ZOOMLION GREEN

## **NEW** ROUGH TERRAIN ZA16JERT ELECTRIC ARTICULATING BOOM LIFT

### HIGHLIGHTS

- ▶ Center layout, great structural rigidity, and small boom deflection
- ▶ Accurate and efficient traveling AC drive system provides strong power and stable control, motor maintenance-free
- ▶ First electrical off-road articulating boom lift of 16m height with strong power suits for complicated working conditions

### FEATURES

#### Standard Features

- ▶ Proportional control
- ▶ All motion alarm
- ▶ Flashing beacon
- ▶ Self-closing entry gate
- ▶ Emergency descent system
- ▶ Emergency stop button
- ▶ Auto-leveling system
- ▶ On-board diagnostic system
- ▶ Over tilt protection system
- ▶ Load sensing system
- ▶ 4.3" LED display
- ▶ Horn
- ▶ Secondary guarding system

#### Accessories & Options

- ▶ AC power to platform
- ▶ Air line to platform
- ▶ Non-marking tire
- ▶ Platform work lights
- ▶ Low-temperature Hydraulic Oil
- ▶ Synthetic Biodegradable Hydraulic Oil

**ZOOMLION**

# ROUGH TERRAIN ELECTRIC ARTICULATING BOOM LIFT

**NEW** ROUGH TERRAIN

**ZA16JERT** Comply with CE/ANSI Standard

Model	ZA16JERT	
	Imperial	Metric
<b>Size</b>		
Work Height	17.8m	58ft 5in
Platform Height	15.8m	51ft 10in
Horizontal Outreach	9.72m	31ft 11in
Up and Over Height	8m	26ft 3in
A - Stowed Length	7.7m	25ft 3in
B - Stowed Width	2.3m	7ft 6in
C - Stowed Height	2.23m	7ft 4in
D - Platform Length	1.83m	6ft
E - Platform Width	0.76m	2ft 6in
Jib Length	1.53m	5ft
F - Wheelbase	2.36m	7ft 9in
G - Ground Clearance	0.36m	1ft 2in
<b>Performance</b>		
Platform Capacity	250kg	550 lb
Drive Speed	6.1km/h	3.79 mph
Gradeability	45%(24°)	
Axles Oscillation	0.20m	8in
Turning Radius (Inside)	2.06m	6ft 9in
Turning Radius (Outside)	4.78m	15ft 8in
Turtable Swing	360° non-continuous	
Platform Rotation	±90°	
H-Tail Swing	0.2m	8in
Max. Wind Speed	12.5m/s	27.96mph
<b>Power</b>		
Battery	24×2V/320Ah	
Charger	48V/35A	
Drive Motor	AC 32V	
Lift Motor	AC 32V	
Auxiliary Power	12V DC Electrical pump	
Hydraulic Tank Capacity	7.9 (us gal)	30L
<b>Tire</b>		
Type	33×12 Foam-filled tire	
<b>Weight</b>		
Gross	16093lb	7300kg

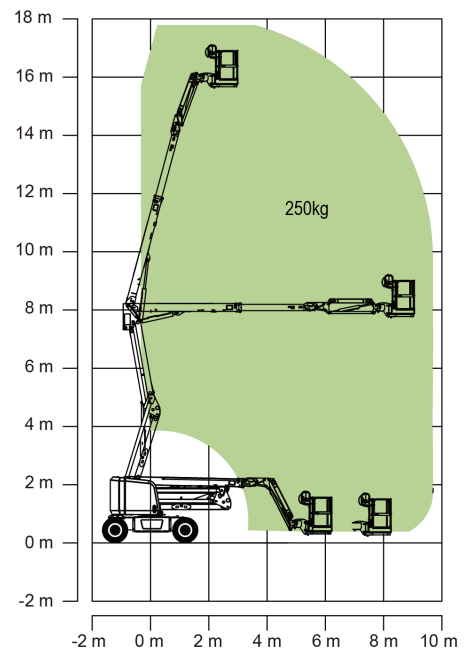
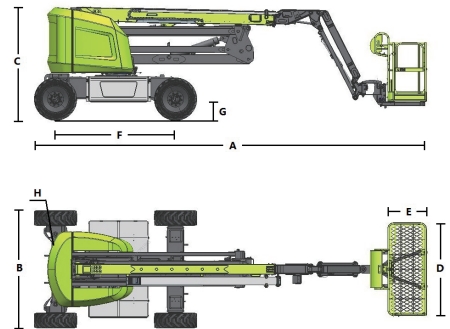

Range of Motion ZA16JERT