

ZOOMLION TELESCOPIC BOOM LIFTS ZT18JE-V (Li)/ZT21JE-V (Li)

Comply with CE/ANSI/CSA Standard



HIGHLIGHTS

- ▶ Pure electric power features green, environmental protection and zero-emission
- ▶ Parallel four-link and two-section/three-section (ZT18JE-V/ZT21JE-V) telescopic boom, dynamic CG and compact structure.
- ▶ Brand-new rough terrain chassis provide gradeability of 45% and strong over-obstacle capacity
- ▶ Accurate traveling AC system and boom movement AC driving system provide strong power and stable control, with maintenance-free motor
- ▶ Common design with high reliability and easy to use
- ▶ Independent auxiliary power system for safety protection
- ▶ Compact design and folded jib, easy to transport

FEATURES

Standard Features

Horn
Proportional control
All motion alarm
Flashing beacon
Self-closing entry gate
Emergency descent system
Emergency stop button
Auto-leveling system
On-board diagnostic system
Tilt protection system
Oscillating axle
Load sensing system
4.3' Led display
Swing-out engine tray

Accessories & Options

- ▶ Platform work light
- ▶ Anti-collision device
- ▶ AC power to platform

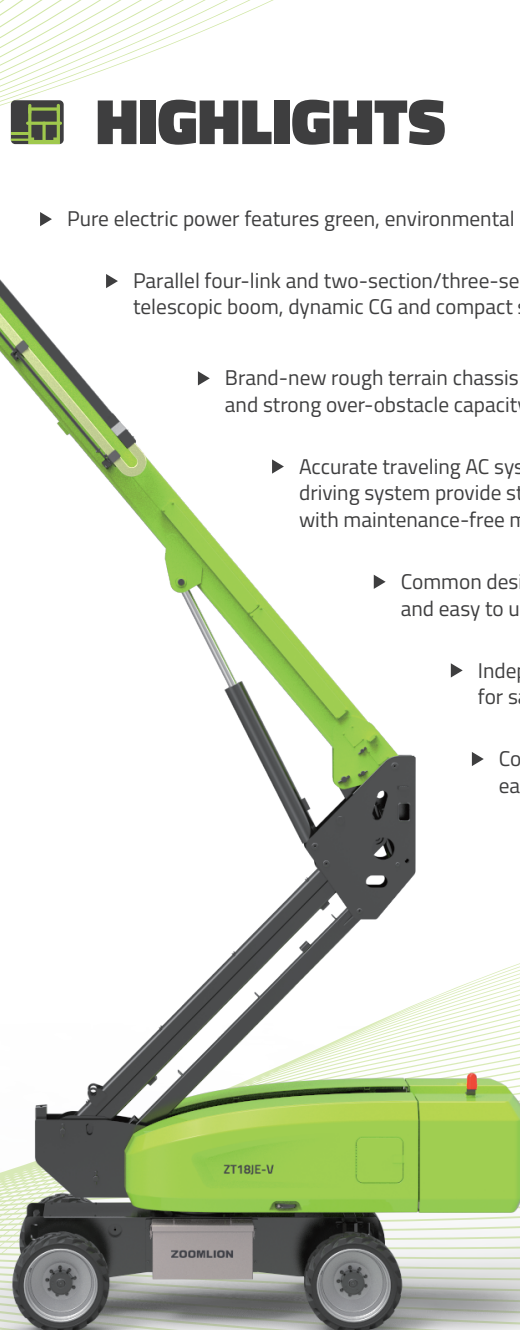

ACCESS WITH ZOOMLION GREEN

Phone: 0086(731)-88353680 0086(731)-88250971
E-mail: awp@zoomlion.com

Add: 701 Xulong Nan Lu, Xiangjiang New District, Changsha Hunan, China
Web: www.zoomlion-access.com

MAIN SPECS OF TELESCOPIC BOOM LIFTS

ZT18JE-V (Li)/ZT21JE-V (Li)

Comply with CE/ANSI/CSA Standard

Model	ZT18JE-V		ZT18JE-V Li		ZT21JE-V		ZT21JE-V Li	
	Imperial	Metric	Imperial	Metric	Imperial	Metric	Imperial	Metric
Size								
Work Height	67ft 7in	20.60m	67ft 7in	20.60m	75ft 4in	22.95m	75ft 4in	22.95m
Platform Height	61ft	18.60m	61ft	18.60m	68ft 9in	20.95m	68ft 9in	20.95m
Horizontal Outreach	43ft 8in	13.3m	43ft 8in	13.3m	50ft 10in	15.5m	50ft 10in	15.5m
A - Stowed Length	31ft 11in (24ft 11in)	9.74m (7.6m)	31ft 11in (24ft 11in)	9.74m (7.6m)	30ft 10in (22ft 4in)	9.4m (6.8m)	30ft 10in (22ft 4in)	9.4m (6.8m)
B - Stowed Width	7ft 6in	2.28m	7ft 6in	2.28m	8ft 1in	2.46m	8ft 1in	2.46m
C - Stowed Height	8ft 5in	2.57m	8ft 5in	2.57m	8ft 10in	2.7m	8ft 10in	2.7m
D - Platform Length	6ft	1.83m	6ft	1.83m	8ft	2.44m	8ft	2.44m
E - Platform Width	2ft 3in	0.76m	2ft 3in	0.76m	3ft	0.91m	3ft	0.91m
F - Wheelbase	8ft 3in	2.52m	8ft 3in	2.52m	8ft 3in	2.52m	8ft 3in	2.52m
Tread	7ft 6in	2.28m	7ft 6in	2.28m	8ft 1in	2.46m	8ft 1in	2.46m
G - Ground Clearance	1ft 1in	0.33m	1ft 1in	0.33m	1ft 1in	0.33m	1ft 1in	0.33m
Performance								
Platform Capacity (Unrestricted/Restricted)	660lb / 300kg	660lb / 300kg	660lb / 300kg	660lb / 300kg	660/1000lb / 300/454kg	660/1000lb / 300/454kg	660/1000lb / 300/454kg	660/1000lb / 300/454kg
Drive Speed (Stowed)	3.23mph / 5.2km/h	3.23mph / 5.2km/h	3.23mph / 5.2km/h	3.23mph / 5.2km/h	3.23mph / 5.2km/h	3.23mph / 5.2km/h	3.23mph / 5.2km/h	3.23mph / 5.2km/h
Gradeability	45%(24°)		45%(24°)		45%(24°)		45%(24°)	
Turning Radius (Inside)	8ft 10in	2.69m	8ft 10in	2.69m	8ft 10in	2.69m	8ft 10in	2.69m
Turning Radius (Outside)	17ft 11in	5.45m	17ft 11in	5.45m	17ft 11in	5.45m	17ft 11in	5.45m
Turntable Swing	360° continuous		360° continuous		360° continuous		360° continuous	
Platform Rotation	±90°		±90°		±90°		±90°	
Tail Swing	5ft 7in	1.7m	5ft 7in	1.7m	5ft 7in	1.7m	5ft 7in	1.7m
Jib Rotation	135°(-60°~75°)		135°(-60°~75°)		130°(-55°~75°)		130°(-55°~75°)	
Max. Wind Speed	28mph	12.5m/s	28mph	12.5m/s	28mph	12.5m/s	28mph	12.5m/s
Power								
Battery	48V/440Ah		51.2V/315Ah (Li)		48V/440Ah		51.2V/375Ah (Li)	
Charger	48V / 60A		48V / 60A		48V / 60A		48V / 60A	
Drive Motor	3.3KW		3.3KW		3.3KW		3.3KW	
Lifting Motor	10KW		10KW		10KW		10KW	
Auxiliary Power	12V DC		12V DC		12V DC		12V DC	
Hydraulic Tank	19 gal	75L	19 gal	75L	19 gal	75L	19 gal	75L
Tire								
Type	Foam-filled tire		Foam-filled tire		Foam-filled tire		Foam-filled tire	
Weight								
Gross	18353lb	8600kg	18353lb	8600kg	22928lb	10400kg	22928lb	10400kg

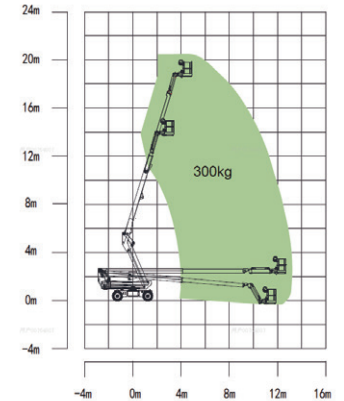
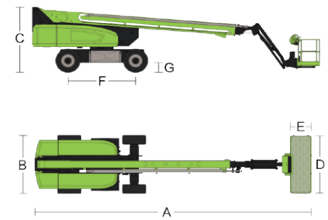

Range of Motion ZT18JE-V (Li)

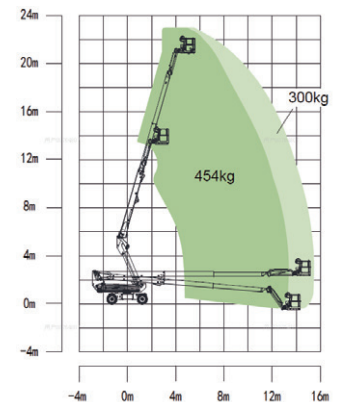

Range of Motion ZT21JE-V (Li)